

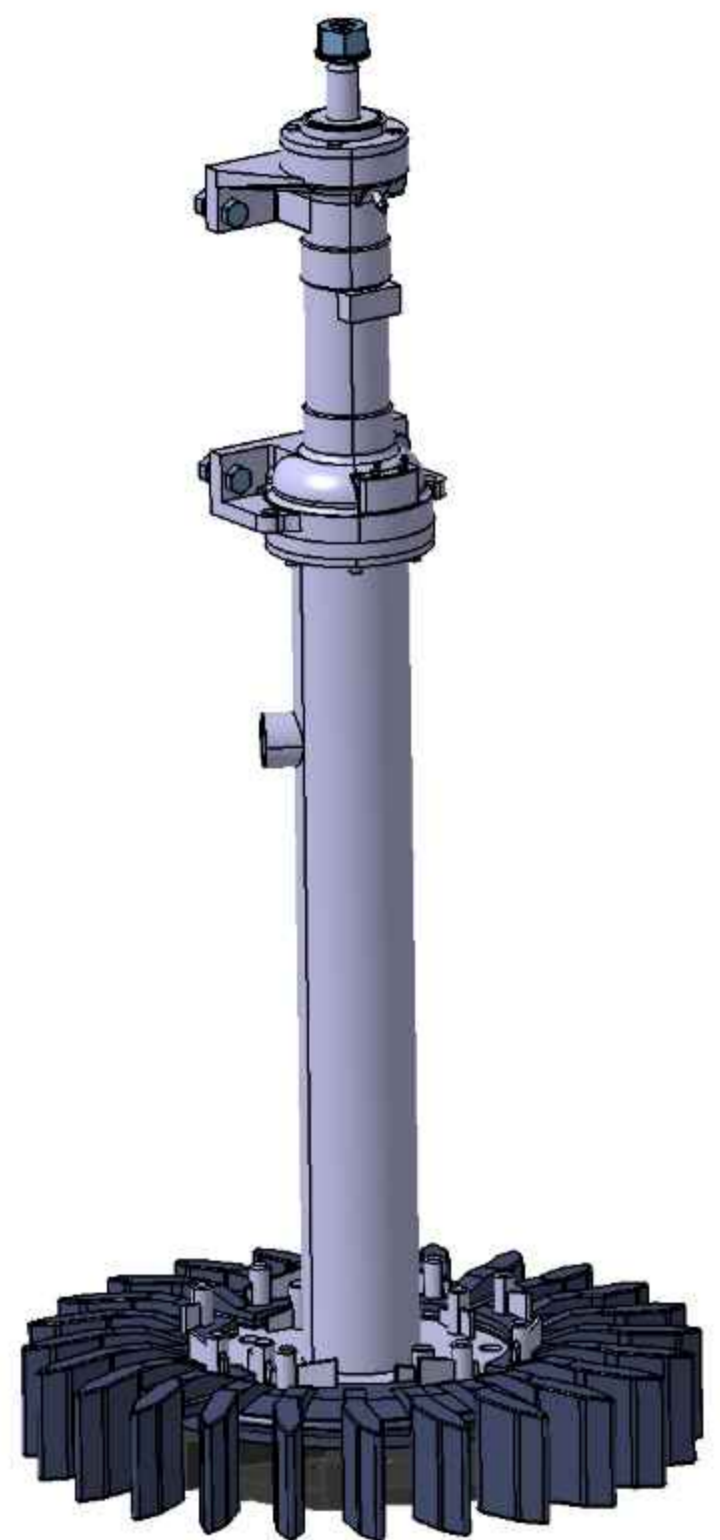

Isometric view
Scale: 1:7



Isometric view
Scale: 1:9

32	Support Pipe 5 1030	1	St37
31	Washer 50 25 5	1	St37
30	Impeller Nut M24 50	1	St37
29	Washer 36*66	1	DIN125
28	Nut M36	1	DIN934
27	Nut M20	4	DIN934
26	Washer 20*37	4	DIN125
25	Bolt M 20*70	4	DIN933
24	Support Pipe Liner 575 220 20	1	NR
23	Wedge Key Pl.6	12	St37
22	Pin 38 78	8	ST37
21	Rubbered Stator 620 360 134	4	NR+ST37
20	Rubbered Rotor 553 184	1	NR+ST37
19	Key 12 8 90	1	St37
18	Key 12 8 55	1	St37
17	Screw M10*50	6	DIN912
16	Bolt M10*25	4	DIN933
15	Grease Nipple 10L30	1	DIN71412
14	Grease 10L10 45	2	DIN 71412
13	Retaining Ring B 90	1	DIN472
12	Seal TC 68 90 10	2	Koyo-DIN3760
11	Drive Shaft 59 35 1750	1	Ck45
10	Lock Nut KM11	1	DIN981
9	Bearing 6411	1	Nachi
8	Lock Washer MB11	1	DIN5406
7	Bearing NU309	1	Nachi
6	Down End Cover 200 70 50	1	GG25
5	Up End Cover 150 57 19	1	GG25
4	Labyrinth 102 40 32	1	GG25
3	Grease Retainer 75 45 13	1	GG25
2	Bush 68 55 50	1	St52
1	Bearing Housing 140 100 470	1	GG25
Item No.	Part Name	QTY	Material/Standard

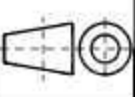
√ (1.6 / 0.8)		01	01	1402/08/30	M.Tolami		
ITEM	REV.NO	DATE	NAME	DESCRIPTION			
Date:	1402/05/30	Project Name:Sala Cell 2800 lit					
Design:	Arshin Machine	Title:					
Drawn:	M.Tolami	Agitator Explode					
Confirmed:	M.Arashmanesh	Assm.No: --					
Approved:	Gh.Zare	Drw.No: --				Scale: 1:1	Rev: 01
Dimension Tolerances:		Material: --	Weight:--kg		Size:A3		
ISO 2768-f		Dimensions : mm	Qty:01		Sheet:01/10		